

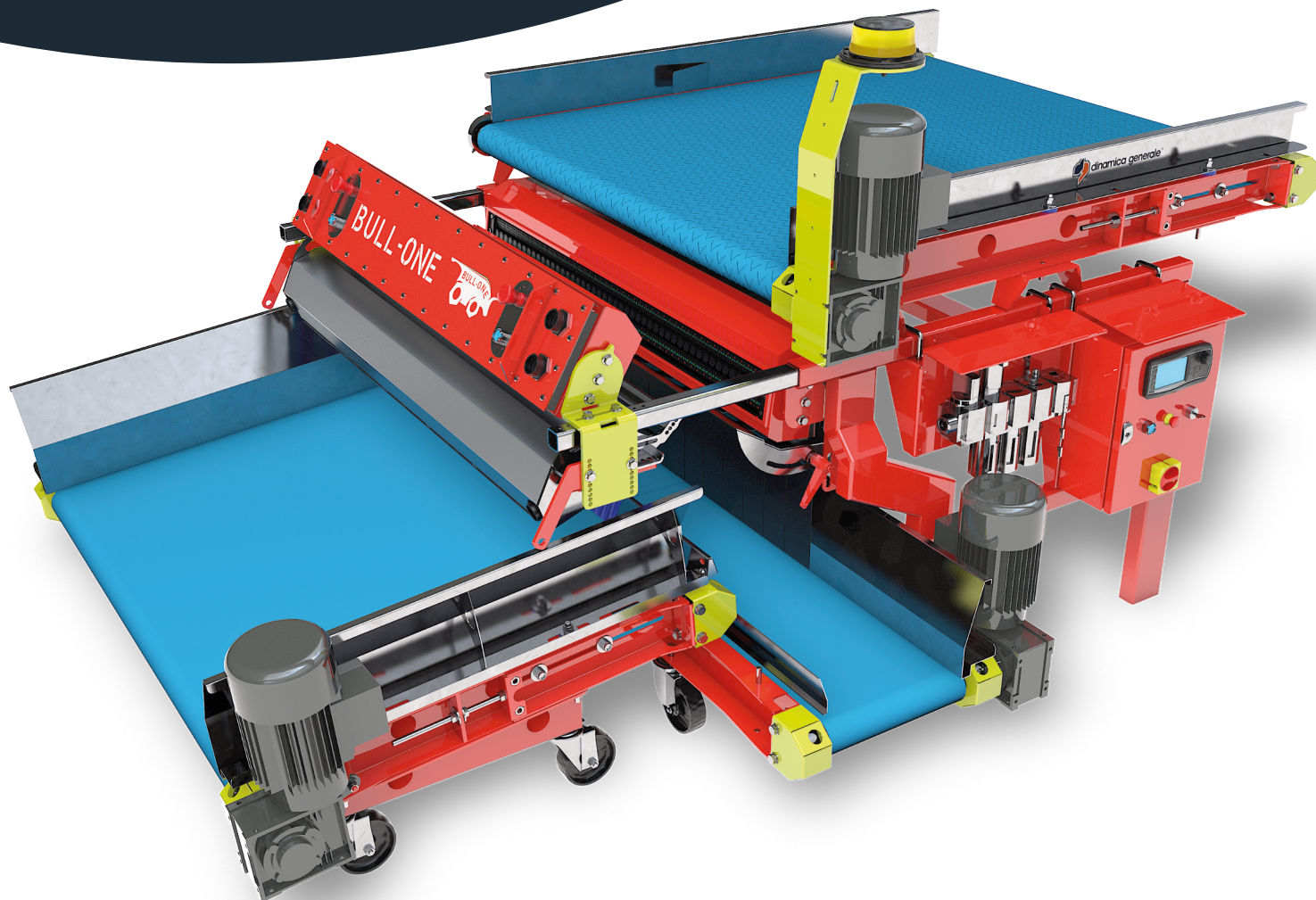

OPTICROP



UNWASHED POTATOES SORTER

Capacity up to

92 T/h

96" Wide

with sensor based
double vision



With a double-vision sensor based sorter equipped with Visible Color and NIR technology (Near Infra Red).

The system can detect organic or inorganic foreign bodies, rotten products and color defects.

Thanks to the 96 channels configuration, the capacity for a large agro and industrial production is guaranteed up to 82 t/h.

The ejection system is made by mechanical fingers pneumatic actuated, manufactured in a special high-resistance and anti-abrasion material.

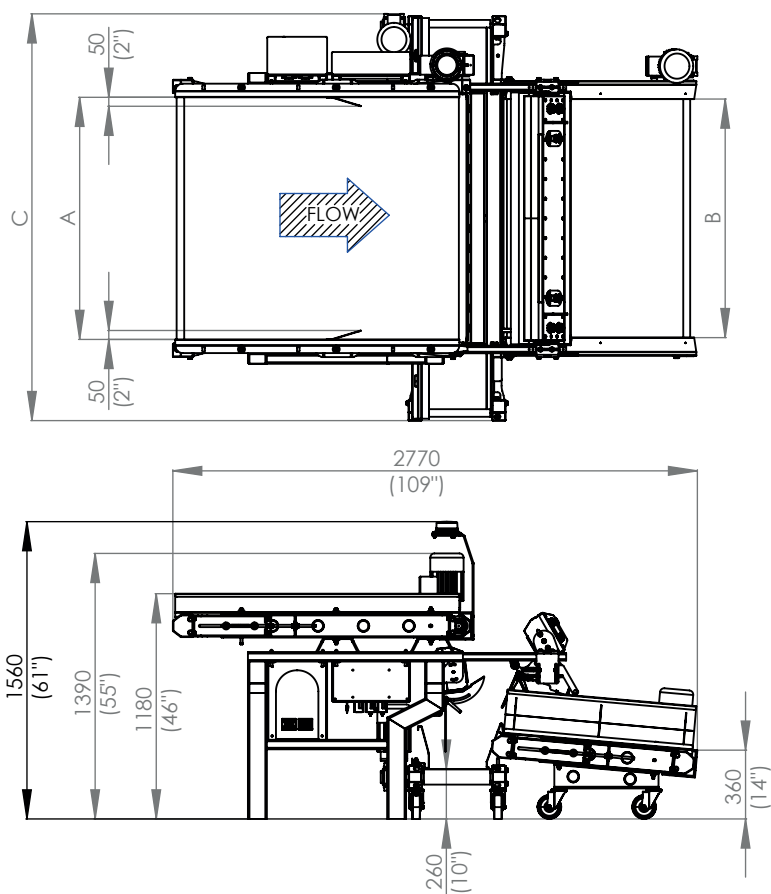

| Version | A | B | C | Capacity |
|---------|------------|------------|-------------|----------|
| 48" | 1270 - 50" | 1270 - 50" | 2140 - 84" | 42 Ton/h |
| 72" | 1880 - 74" | 1880 - 74" | 2745 - 108" | 62 Ton/h |
| 96" | 2490 - 96" | 2490 - 96" | 3400 - 134" | 84 Ton/h |



Other Applications



Dinamica Generale S.p.A.
 Via Mondadori 15, 46025 Poggio Rusco MN, Italia
 Tel.: +39 0386 52134 Fax: +39 0386 51523
 info@dinamicagenerale.com

